

Sunfab's SCM 010-130 SAE is a range of robust axial piston motors especially suitable for mobile hydraulics.

SCM 010-130 SAE is of the bent-axis type with spherical pistons. The design results in a compact motor with few moving parts, high starting torque and high reliability. It covers the entire displacement range 10-130 cm³/rev. at a maximum pressure of 400 bar. It features double tapered roller bearings, which permits high shaft loads and gives superb speed performance.

The high level of reliability is based on the choice of materials, hardening methods, surface structures and the quality assured manufacturing process.

Sunfab also offers a two-bolt flange, SAE B2 010- 034 in the SCM family. The design features double tapered roller bearings, which permits high shaft loads and gives superb speed performance.

Other advantages:

- High maximum speed
- Smooth operation over the entire speed range
- Available in many different configurations of shafts and connections
- High efficiency
- Speed sensor available as option
- Suitable for applications with high angular accelerations due to its high rotary stiffness

Versions, main data

Example

SC	M	-	012	W	-	P	-	SB4	-	B13	-	S3	U	-	1	00
Line	1		2	3		4		5		6		7	8		9	10

Line	SC	Sunfab Compact, bent-axis design
------	----	----------------------------------

1. Type	M	Motor
---------	---	-------

2. Displacement	010 010 012 017 025 034 040 047 056 064 084 090 108 130
-----------------	---

3. Direction of rotation	W	Independent
--------------------------	---	-------------

4. Sealing	P	FPM, high pressure, high temperature
For low temperature applications, below -25 °C please contact Sunfab.		

5. Mounting flange	SAE J-744	010 012 017 025 034 040 047 056 064 084 090 108 130
SB2	SAE B-2 hole	X X X X X - - - - - - - - -
SB4	SAE B-4 hole	X X X X X - - - - - - - - -
SC4	SAE C-4 hole	- - - X X X X X X X X X -
SD4	SAE D-4 hole	- - - - - - - - - X X X X

6. Shaft	010 012 017 025 034 040 047 056 064 084 090 108 130	
Spline ANSI B92.1 30° Class 5		
B13	13T 16/32***	X X X X X - - - - - - - - -
C14	14T 12/24*	- - - X X X X X X X X O O -
C21	21T 16/32*	- - - - - X X X X X X X X -
D13	13T 8/16**	- - - - - - - - - X X X X
Key SAE J744		
B22	ø 22.22	X X X - - - - - - - - -
B25	ø 25.4 ***	X X X X X - - - - - - - - -
C32	ø 31.7*	- - - - - X X X X O O O -
D44	ø 44.45 **	- - - - - - - - - X X X X

* Only with SC4 mounting flange
 ** Only with SD4 mounting flange
 *** Only with SB2/SB4 mounting flange

- = Not available
 X = Standard, preferred
 O = Contact Sunfab

7. Connection cover		010 012 017 025 034 040 047 056 064 084 090 108 130
S1	40° Mount flange vertical *	- - - - - - - - - X X X X
S2	40° Mount flange horizontal *	- - - X X X X X X - - - -
S3	40° Threaded connection	X X X X X - - - - - - - -
V1	90° Mount flange vertical *	- - - - - - - - - X X X X
V2	90° Mount flange horizontal *	- - - X X X X X X X X X X
R1	Side connections, flanged *	- - - X X X X X X X X X X
K3	Combicover 90° side conn. thread	X X X X X - - - - - - - -

* According to SAE J518 code 62

8. Connections		010 012 017 025 034 040 047 056 064 084 090 108 130
G	ISO G*	X X X X X - - - - - - - -
M	Metric **	- - - X X X X X X X X X X
U	UN***	X X X X X X X X X X X X X

* Only threaded connections
 ** Only flanged connections
 *** Not available for K3

9. Accessories		External drainage
1		

10. Speed Sensor		010 012 017 025 034 040 047 056 064 084 090 108 130
00	No Speed Sensor	X X X X X X X X X X X X X
P1	Prepared for Speed Sensor	X X X X X X X X X X X X X
S1	Fitted Speed Sensor type PNP*	X X X X X X X X X X X X X
S2	Fitted Speed Sensor type NPN*	X X X X X X X X X X X X X

* See separate brochure "Speed Sensor hall" for more information.

SCM 010-130 SAE

		010	012	017	025	025	034	034	040	047	056	064	084	084	090	090	108	108	130	
		SAE B	SAE B	SAE B	SAE B	SAE C	SAE B	SAE C	SAE C	SAE C	SAE C	SAE C	SAE C	SAE D	SAE C	SAE D	SAE C	SAE D	SAE D	
Displacement	cm ³ /rev	9.6	12.6	17.0	25.4	25.4	34.2	34.2	41.2	47.1	56.7	63.5	83.6	83.6	90.7	90.7	108.0	108.0	130.0	
Working pressure																				
<i>max intermittent</i>	bar	400	400	400	400	400	400	400	400	400	400	400	400	400	400	400	400	400	400	350
<i>max continuous</i>		350	350	350	350	350	350	350	350	350	350	350	350	350	350	350	350	350	350	300
Revolutions																				
<i>max intermittent</i>	rpm	8250	8250	8250	6500	6500	6500	6500	5900	5900	5900	5900	4800	4600	4800	4600	4800	4600	4800	4600
<i>max continuous</i>		7500	7500	7500	5900	5900	5900	5900	5300	5300	5300	5300	4400	4200	4400	4200	4400	4200	4400	4200
<i>min continuous</i>		300	300	300	300	300	300	300	300	300	300	300	300	300	300	300	300	300	300	300
Power																				
<i>max intermittent</i>	kW	41	50	70	80	80	110	110	120	135	165	180	200	190	215	205	255	245	255	255
<i>max continuous</i>		15	20	25	40	40	55	55	60	65	80	90	100	100	110	110	130	130	135	135
Starting torque theoretical value	Nm/bar	0.15	0.20	0.27	0.40	0.40	0.54	0.54	0.66	0.75	0.89	1.00	1.33	1.33	1.44	1.44	1.71	1.71	1.71	2.06
Moment of inertia (x 10 ⁻³)	kg m ²	0.9	0.9	0.9	1.1	1.1	1.1	1.1	2.6	2.6	2.6	2.6	6.3	7.4	6.3	7.4	6.3	7.4	6.3	7.4
Weight	kg	9.0	9.0	9.0	9.0	9.0	9.0	9.0	15.0	15.0	15.0	15.0	18.0	35.0	18.0	35.0	18.0	35.0	18.0	35.0

Data concerning RPM are based on maximum permitted peripheral velocity of the tapered roller bearing.
Max intermittent power data may vary dependent on application. For further information please contact Sunfab.
Continuous power data are based on maximum output power without external cooling of the motor housing.
Intermittent duty is defined as follows: max 6 seconds per minute, e.g peak RPM when unloading or accelerating.

Dimensions SCM 010-034 SB2 & SB4 Flange & shafts

Millimeter (inch)

SB2 SAE J744, ID. Code: 101-2 (B)

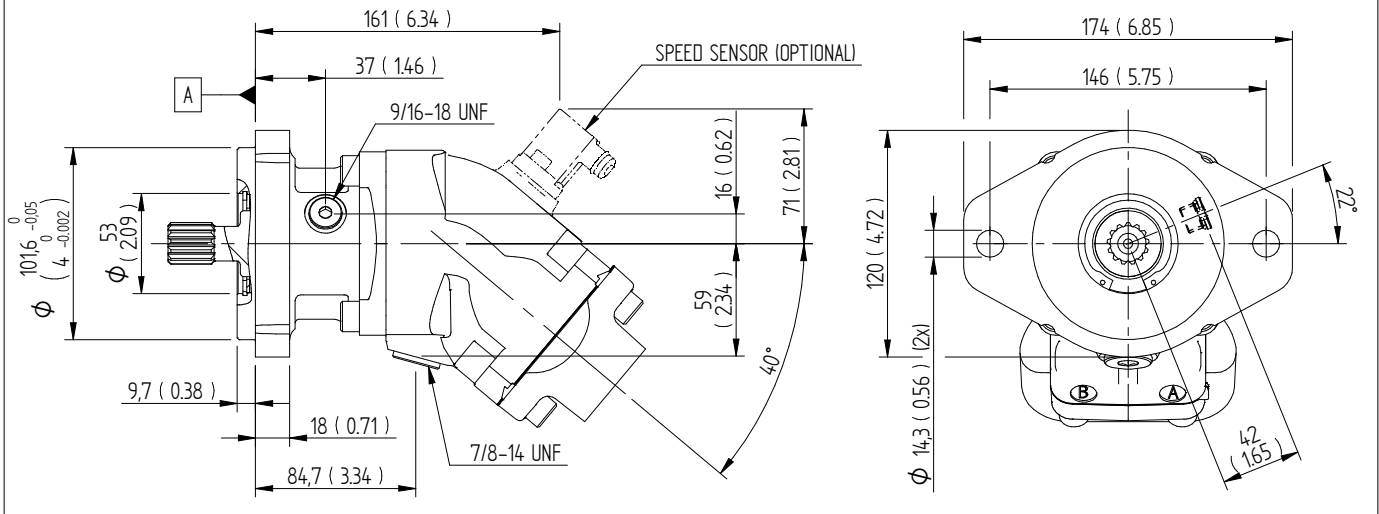

SB4 SAE J744, ID. Code: 101-4 (B)

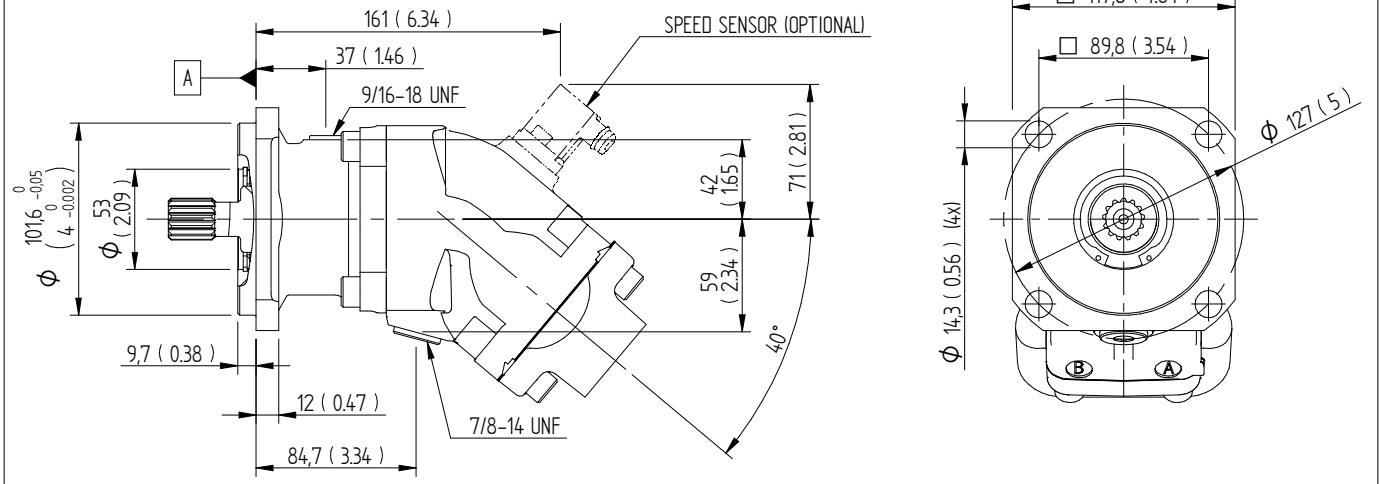

B13 SAE J744, ID. Code: 22-4 (B)

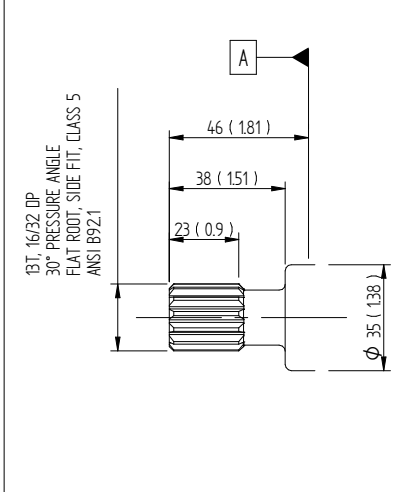

B25 SAE J744, ID. Code: 25-1 (B-B)

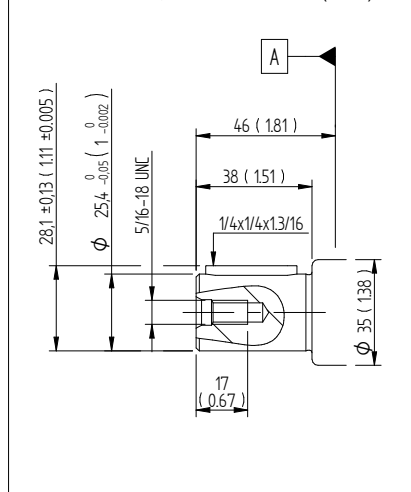

B22 SAE J744, ID. Code: 22-1 (B) (010-017 ONLY)

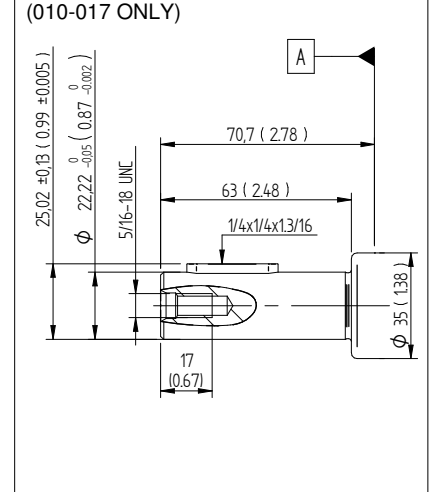

Dimensions SCM 010-034 SB2 & SB4

Connection cover

Millimeter (inch)

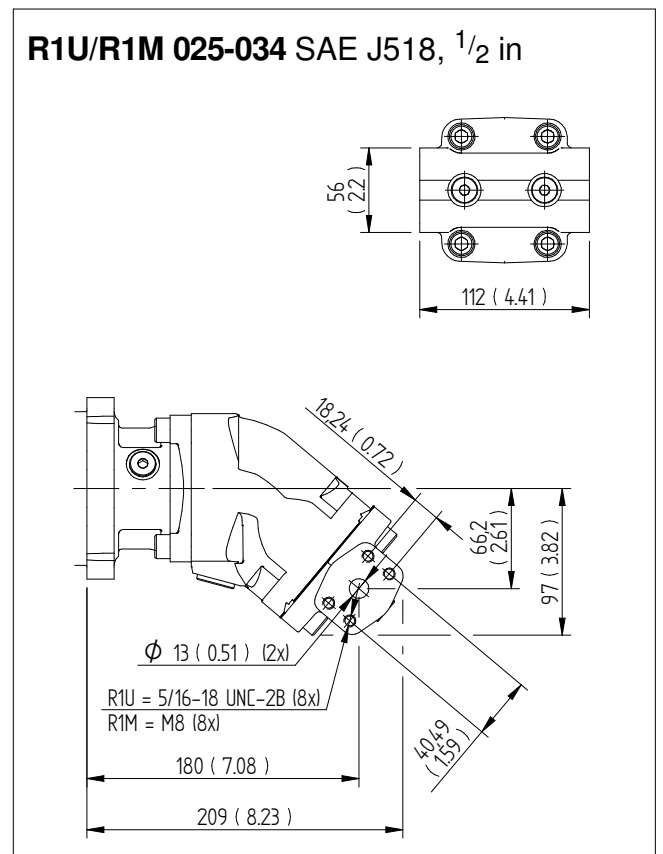
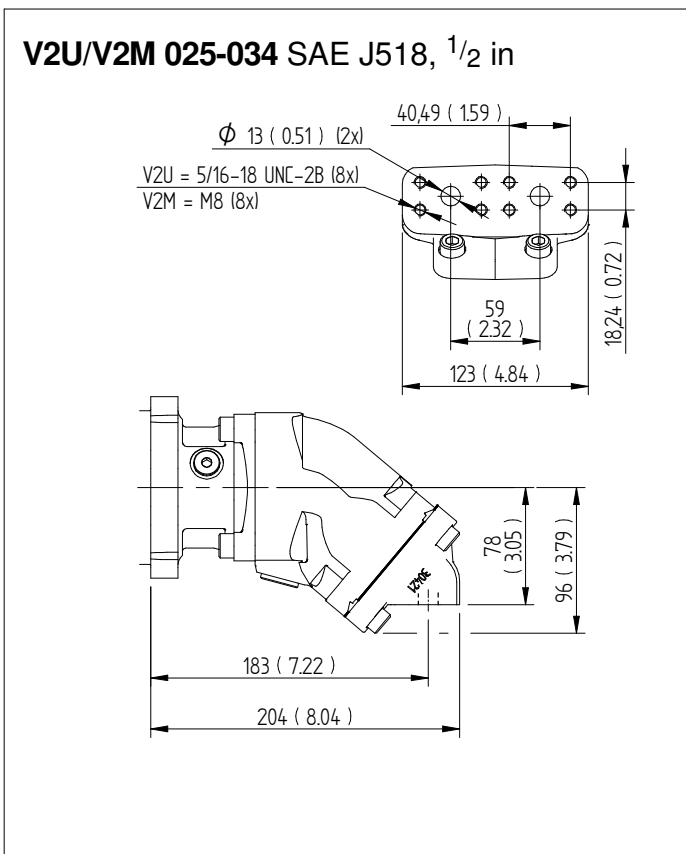
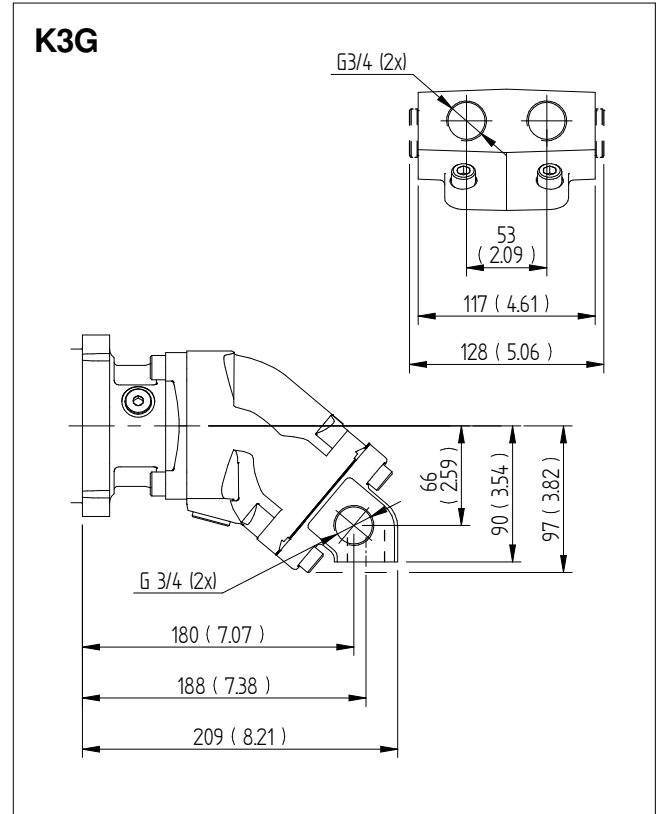
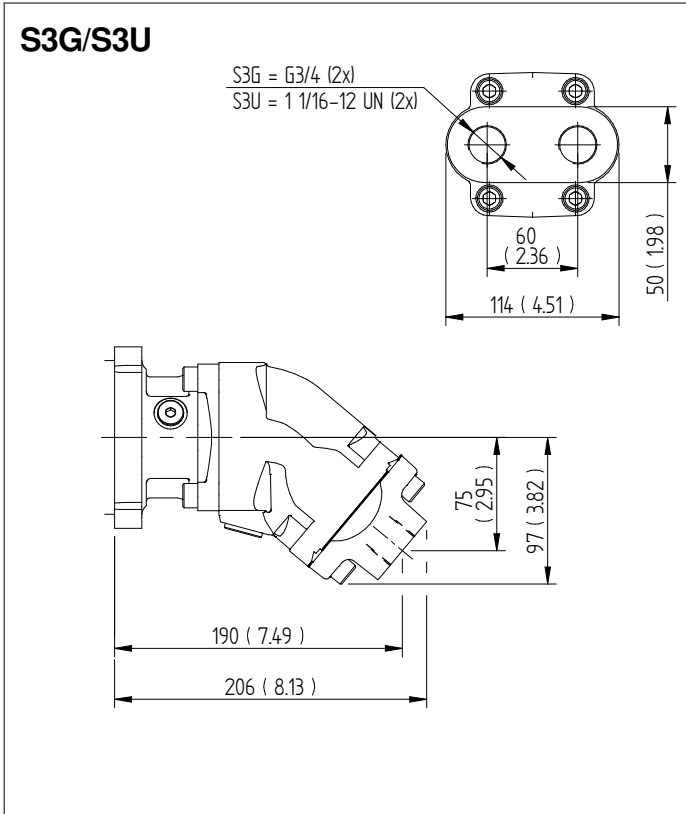

Dimensions SCM 010-034 SB2 & SB4

Connection cover

Millimeter (inch)

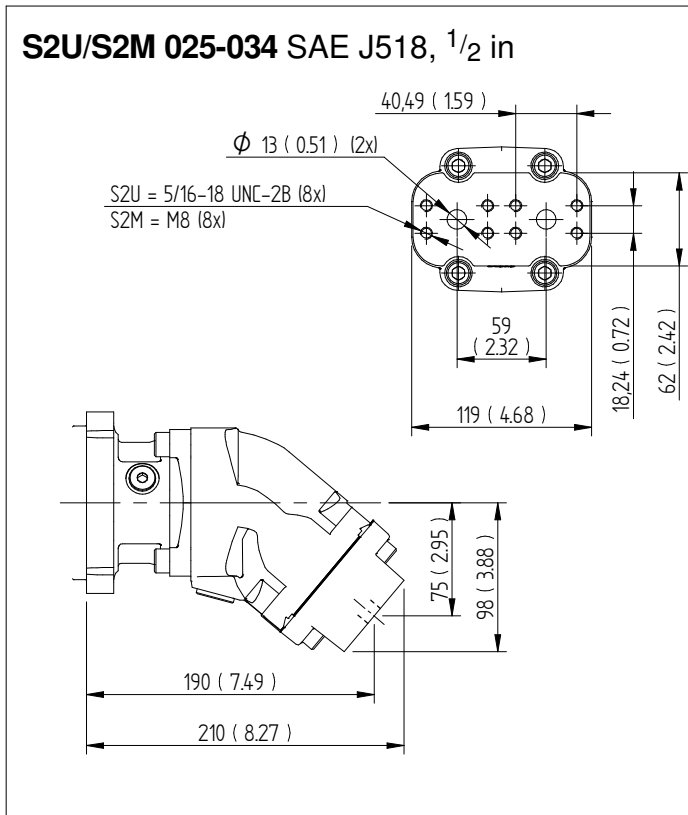

Dimensions SCM 025-034 SC4 Flange & shafts

Millimeter (inch)

SC4 SAE J744, ID. Code: 127-4 (C)

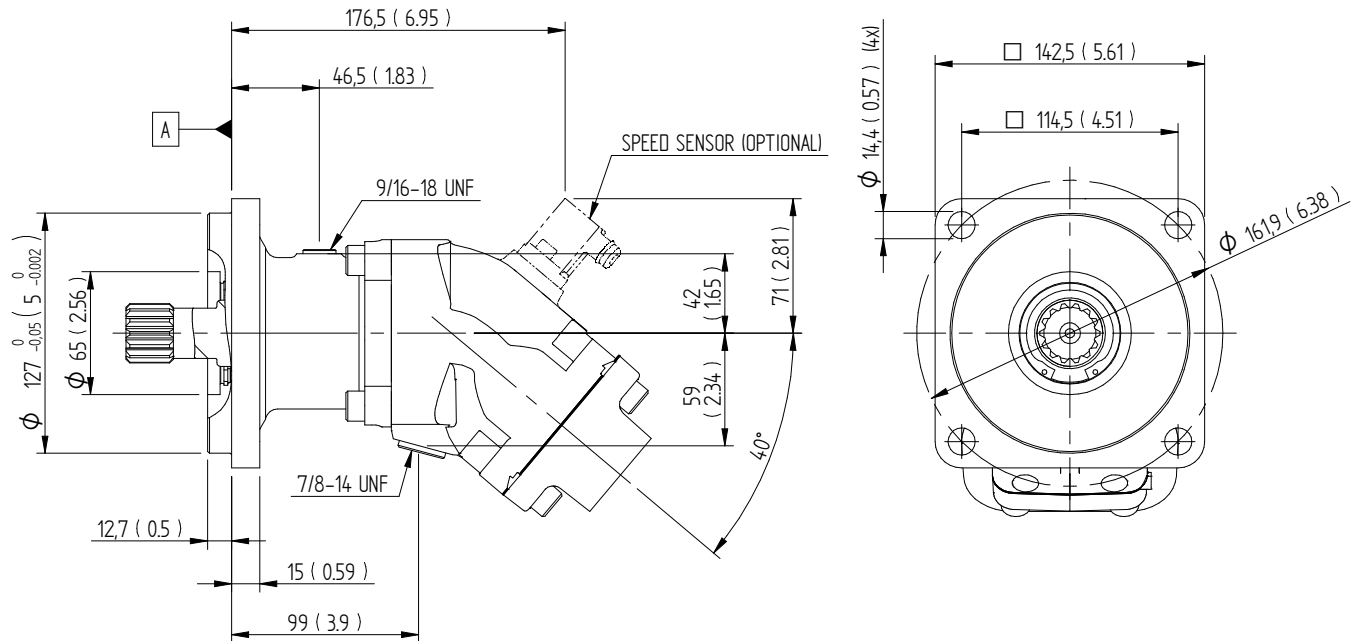

C14 SAE J744, ID. Code: 32-4 (C)

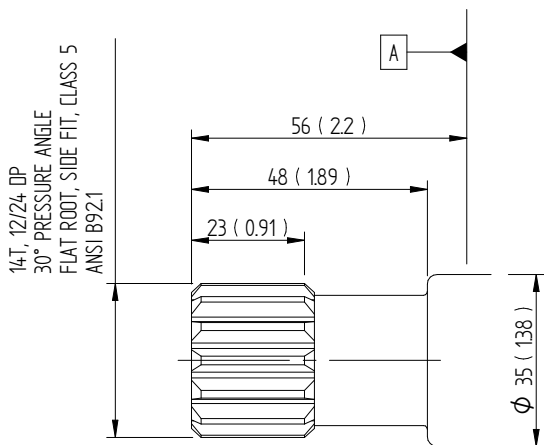

Dimensions SCM 025-034 SC4

Connection cover

Millimeter (inch)

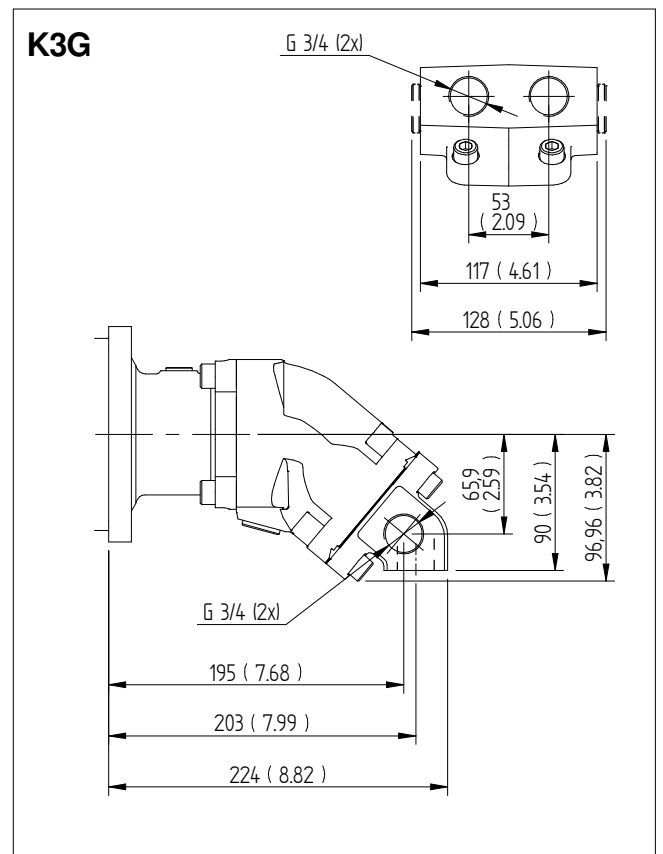
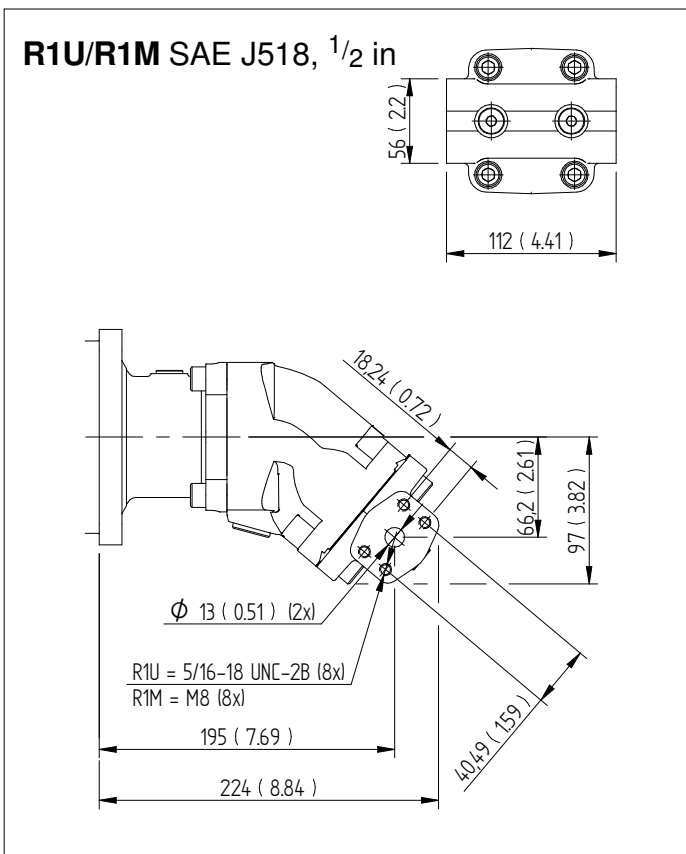
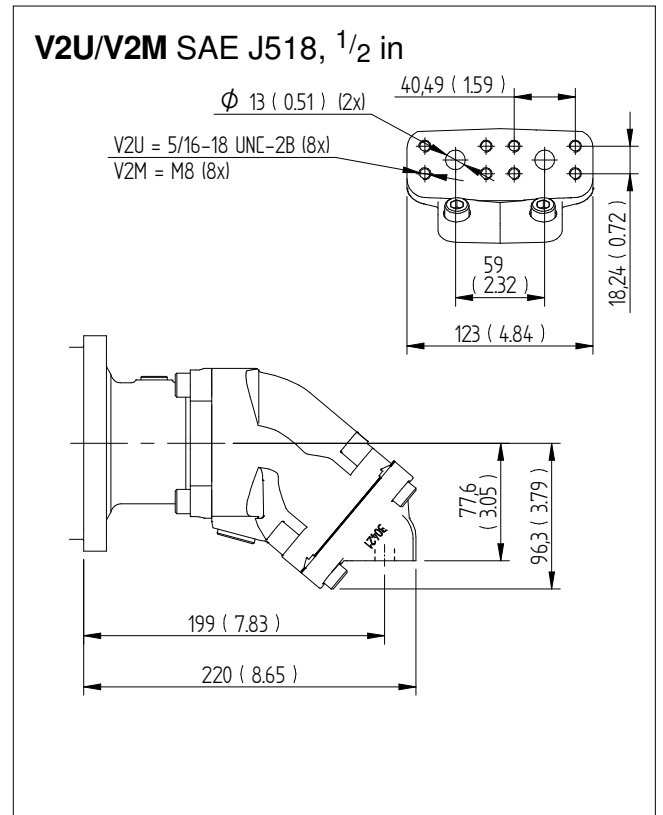
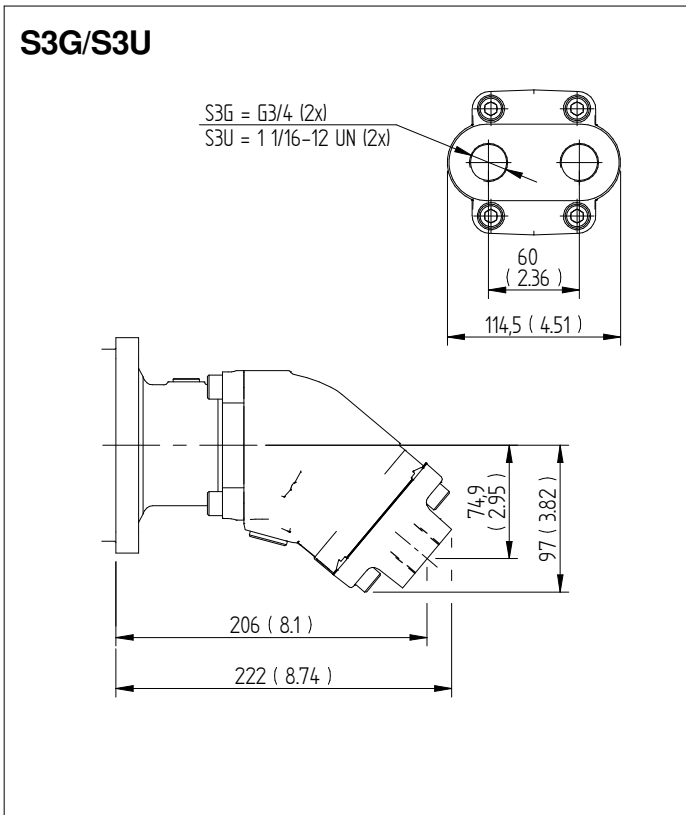

Dimensions SCM 025-034 SC4

Connection cover

Millimeter (inch)

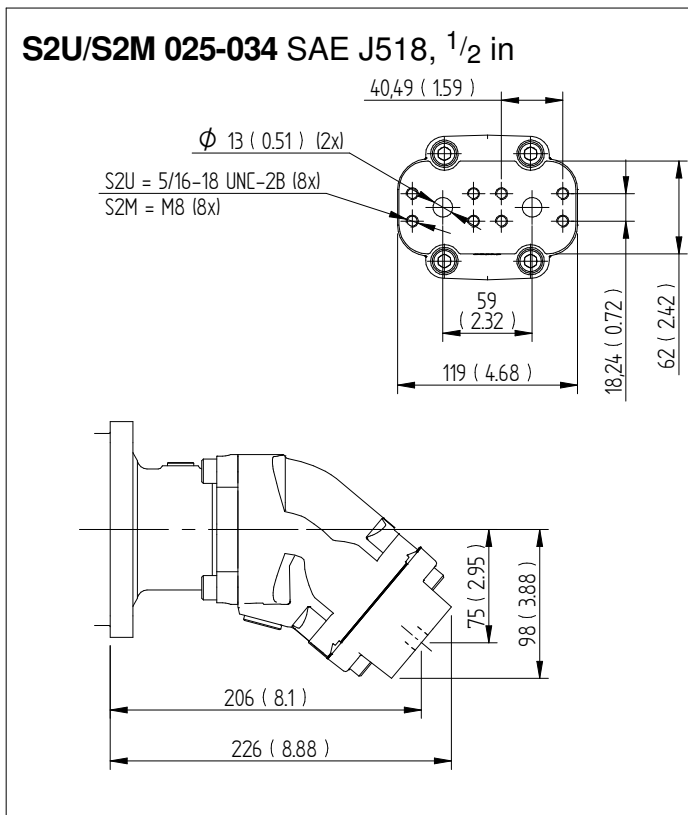

Dimensions SCM 040-064

Flange & shafts

Millimeter (inch)

SC4 SAE J-744, ID. Code: 127-4 (C)

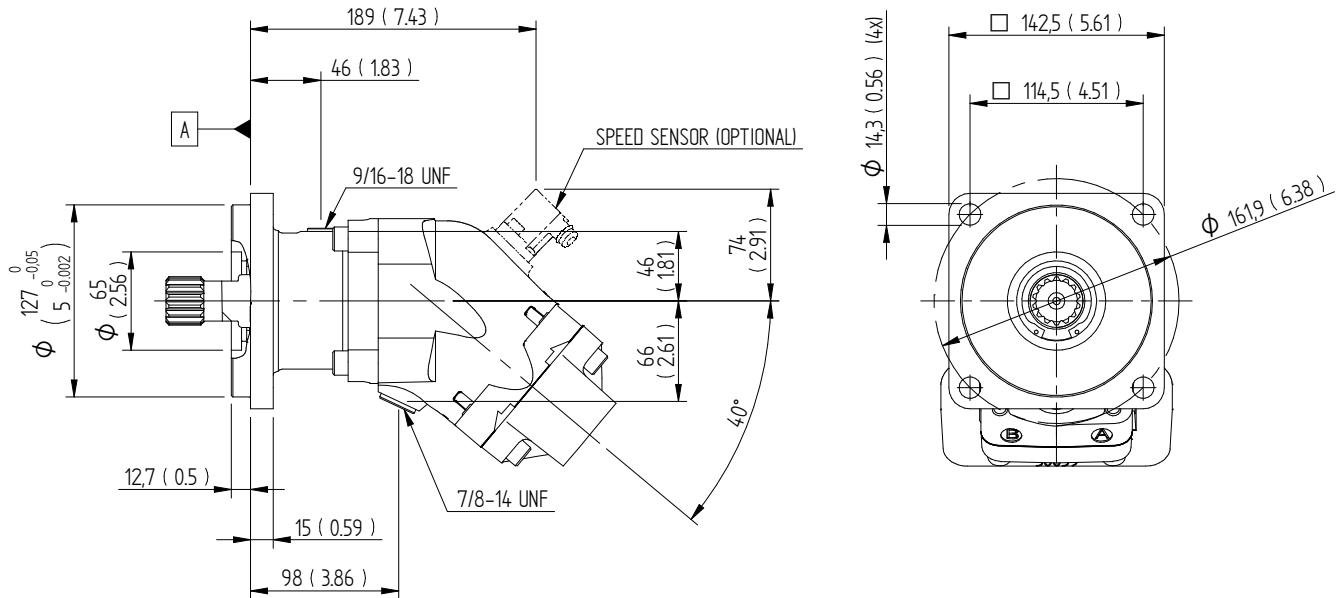

C14 SAE J744 ID. Code: 32-4 (C)

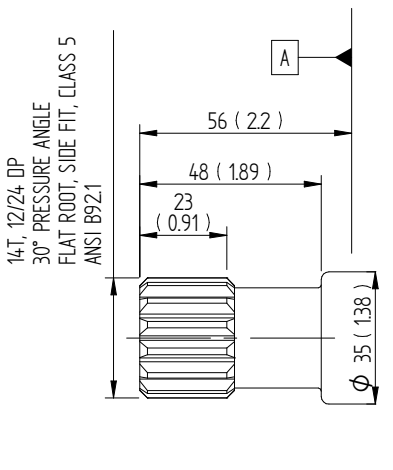

C21 SAE J744

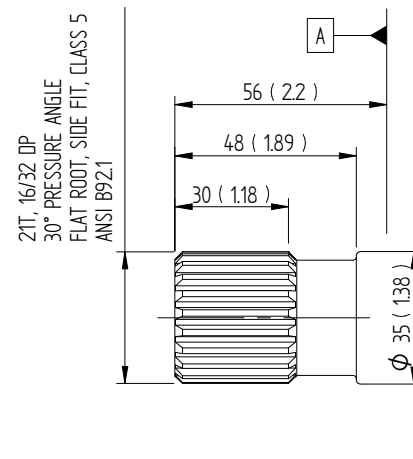

C32 SAE J744 ID. Code: 32-1 (C)

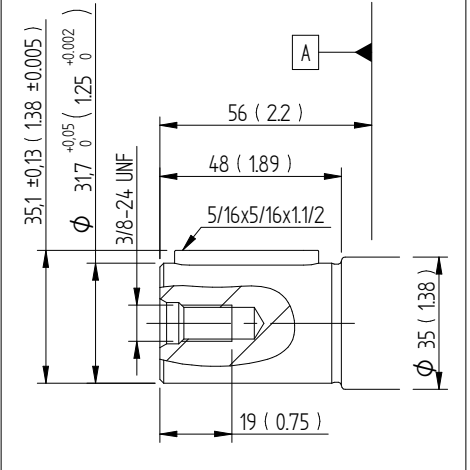

Dimensions SCM 040-064

Connection cover

Millimeter (inch)

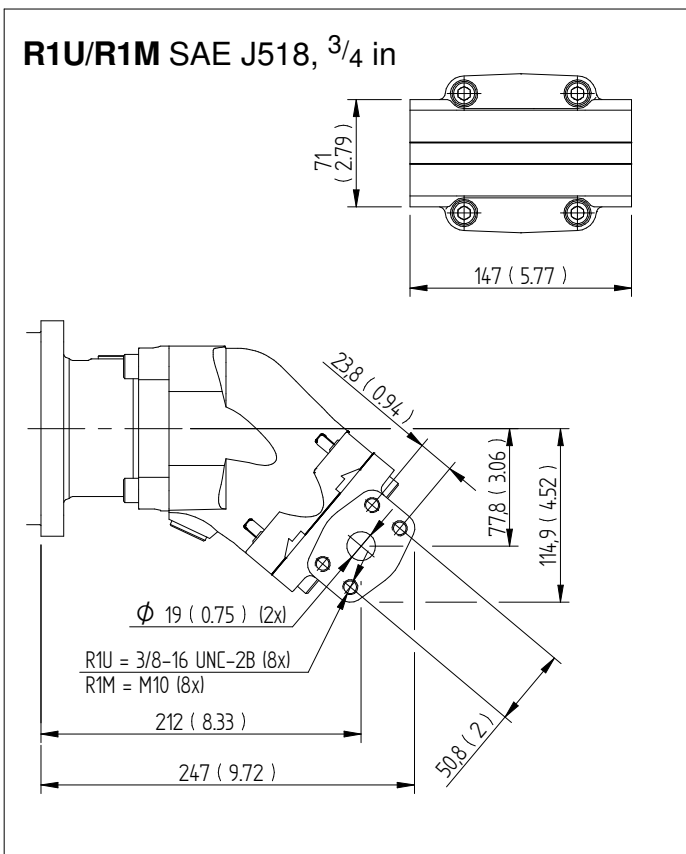
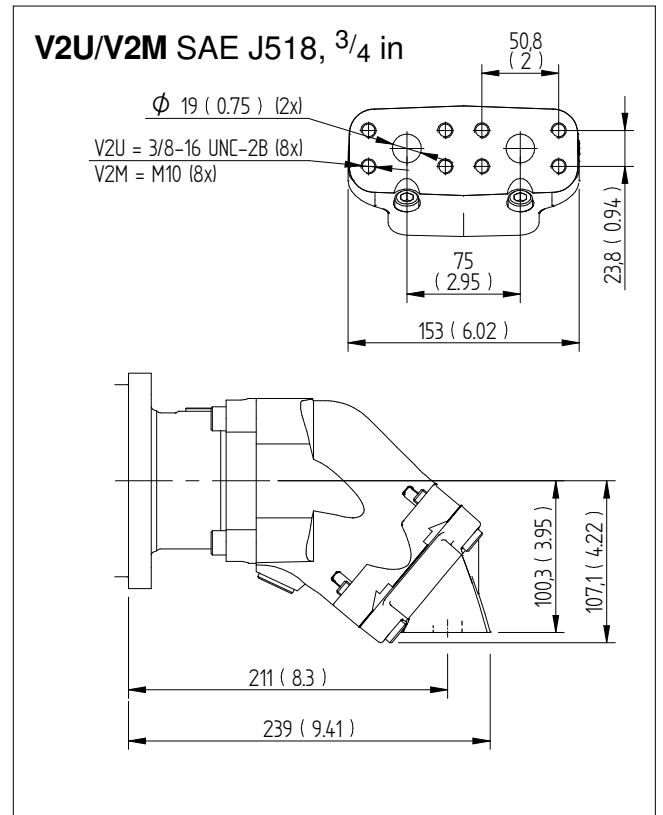
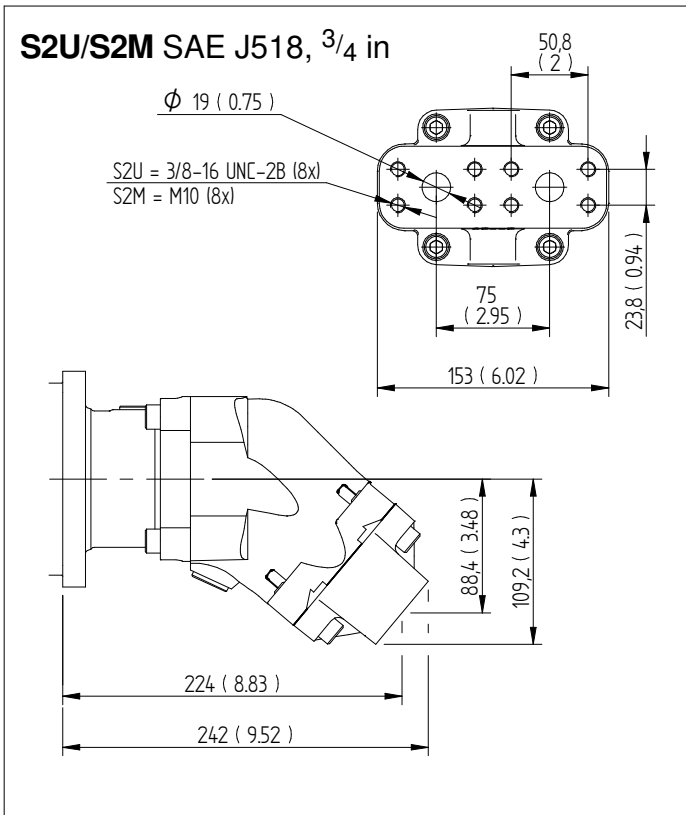

Dimensions SCM 084-108

Flange & shafts

Millimeter (inch)

SC4 SAE J-744, ID. Code: 127-4 (C)

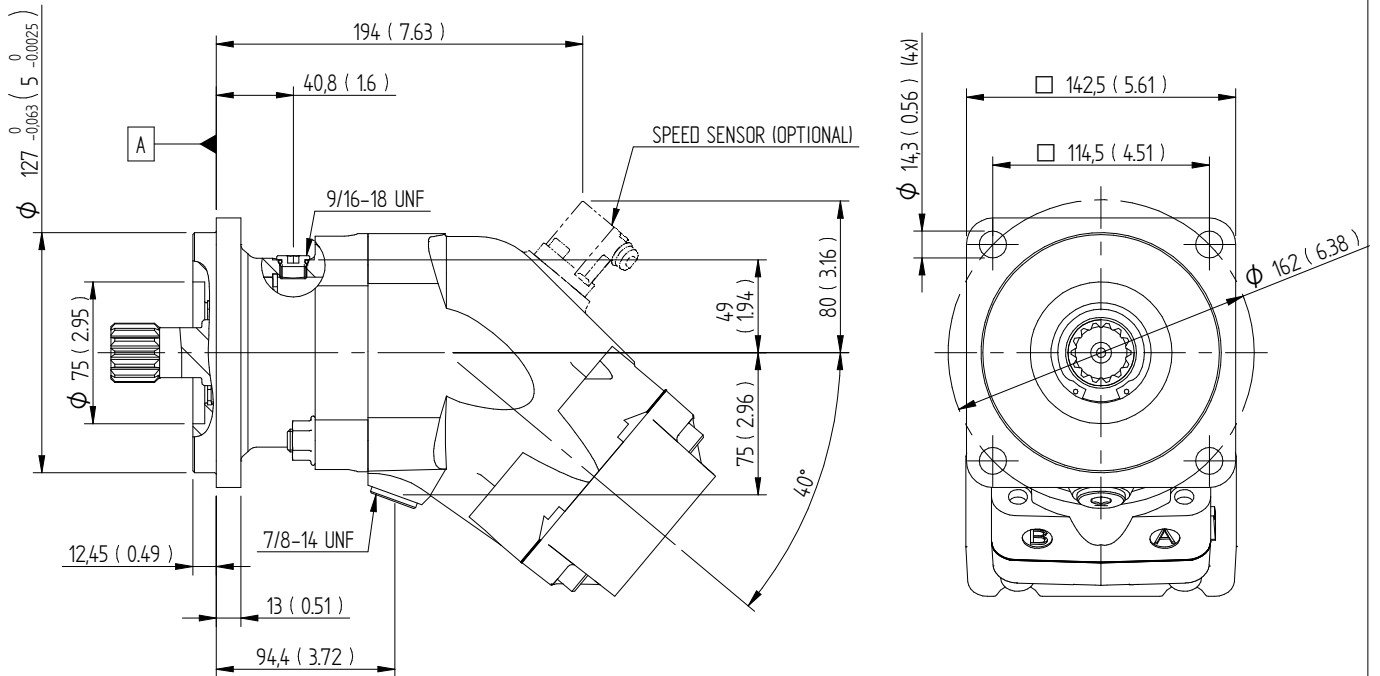

C14 SAE J744 ID. Code: 32-4 (C)

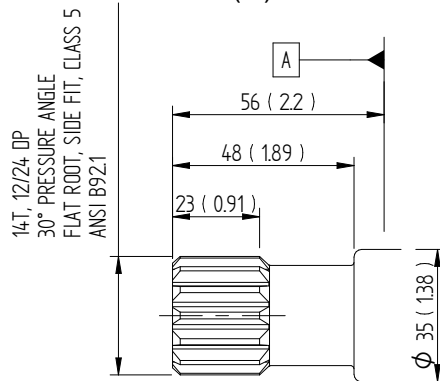

C32 SAE J744 ID. Code: 32-1 (C)

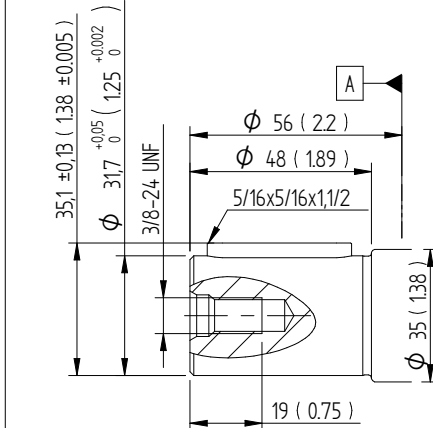

C21 SAE J744

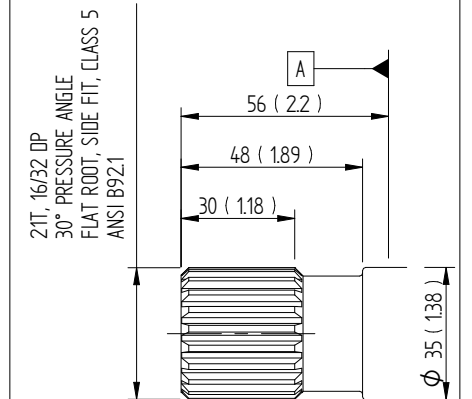

Dimensions SCM 084-108

Connection cover

Millimeter (inch)

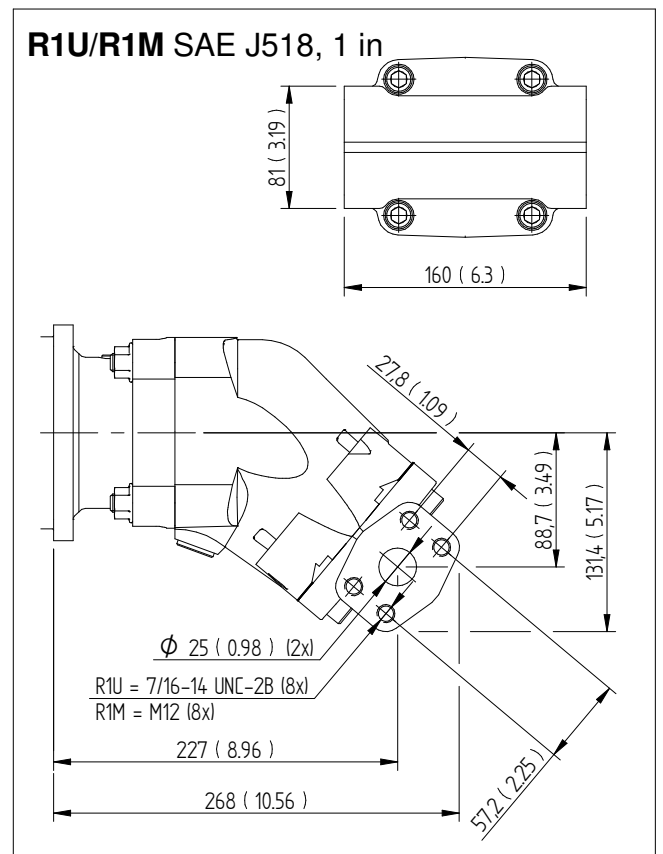
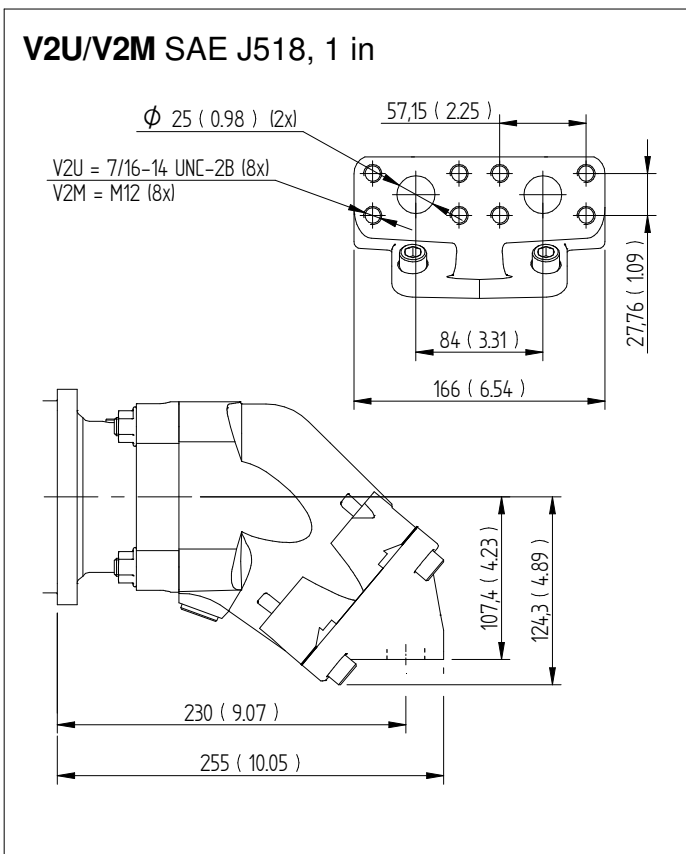
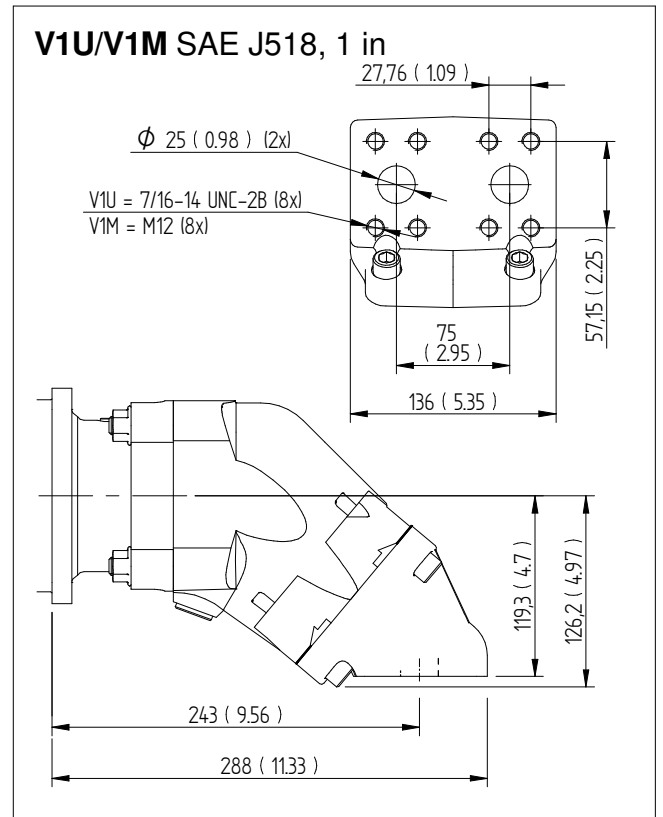
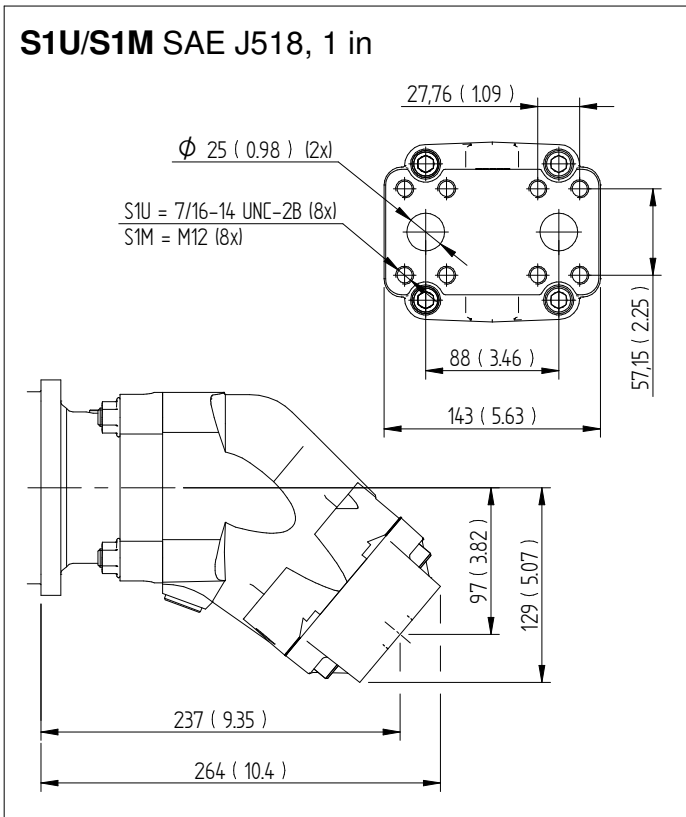

Dimensions SCM 084-130

Connection cover

Millimeter (inch)

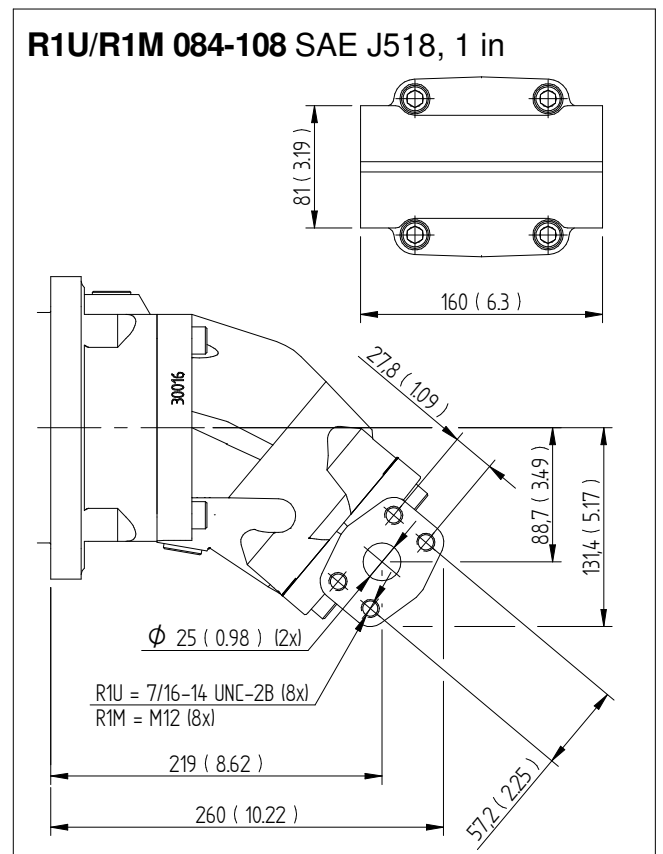
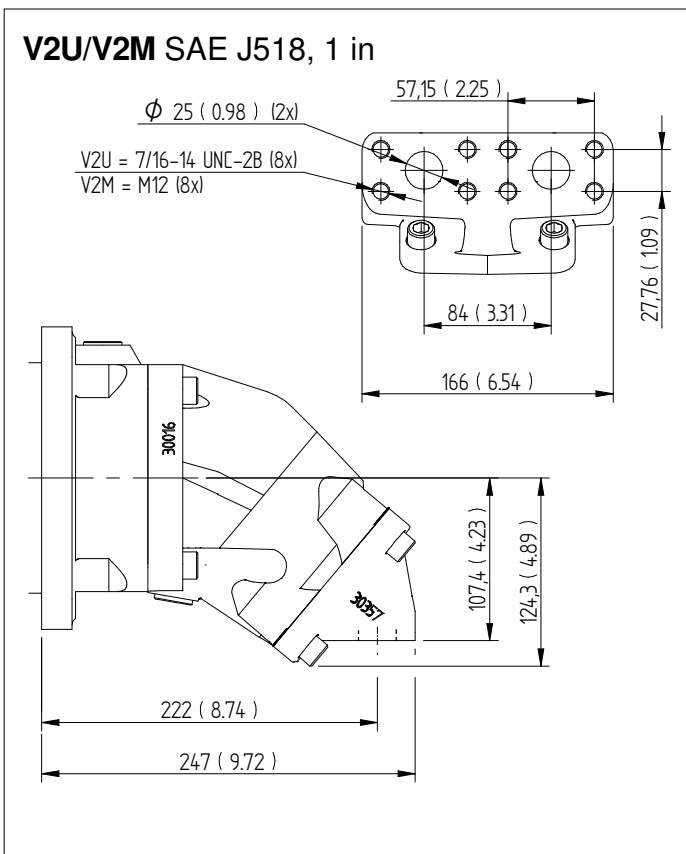
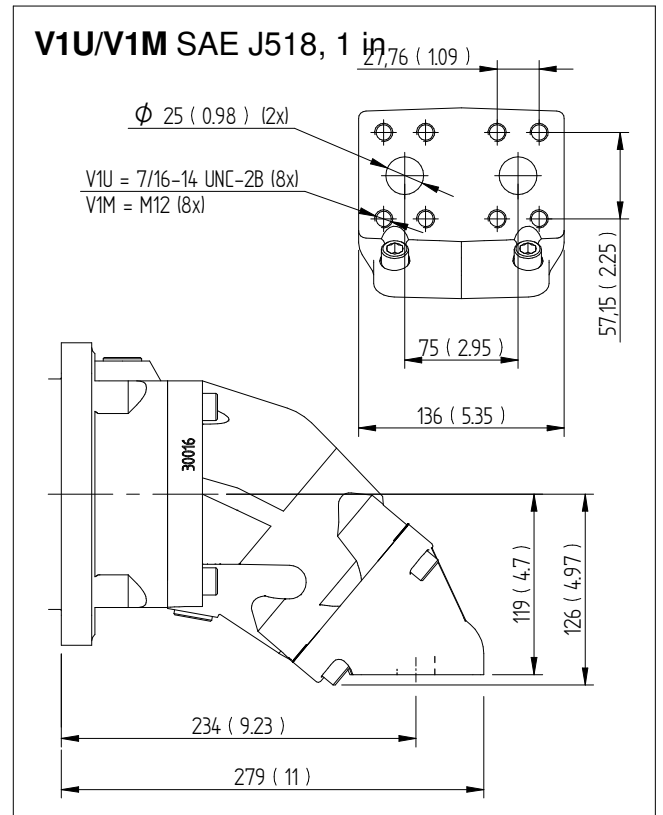
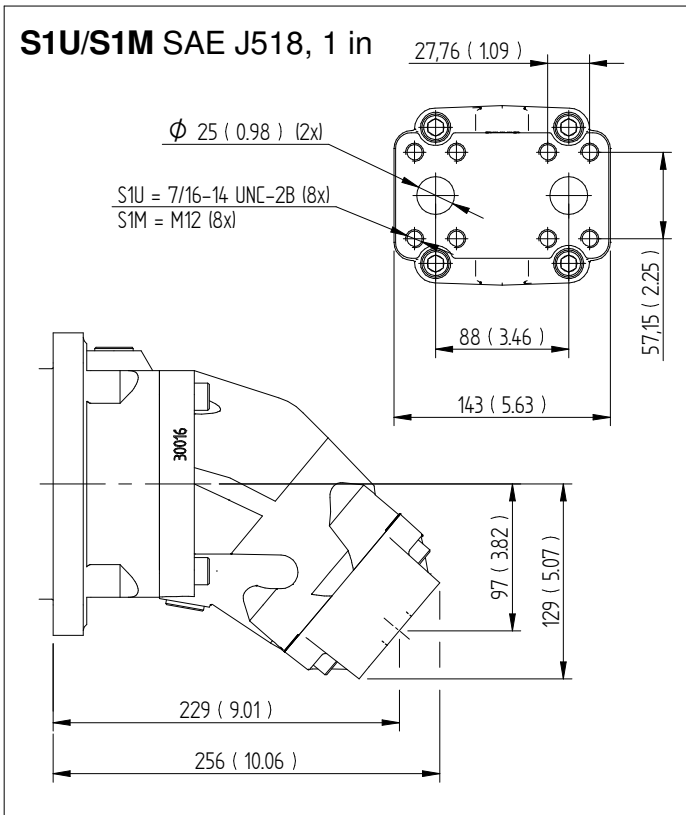

General instructions

Shaft seal

Motor SCM	Code	Max. housing pressure bar at rpm				
		1500	3000	5200	6300	8250
010-034	P	7	7	4	3.5	2.5
040-064	P	7	6	3.5	3	-
084-130	P	7	4	3	-	-

Code according to page 2. Versions main data.

For low temperature applications, below -25 °C please contact Sunfab.

The drainage oil should have a maximum temperature of 115 °C with the P shaft seal. This temperature must not be exceeded.

The housing pressure must be equal to or greater than the external pressure on the shaft seal.

To ensure the function of the shaft seal and lubrication of the motor, we recommend a min. housing pressure of 0,5 bar. If needed, a spring loaded check valve of 0,5 bar can be installed on the housing drain line.

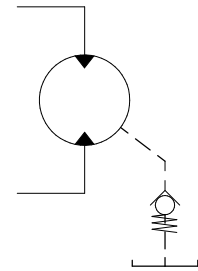

Shaft loads

The life of the motor is highly dependent on the bearing life. The bearings are affected by operating conditions such as speed, pressure, oil viscosity and filtration.

External load on the shaft, as well as its size, direction and location also affects the bearing life.

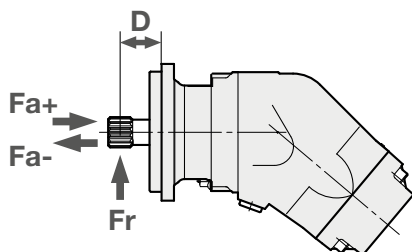

Optimal force direction of radial load

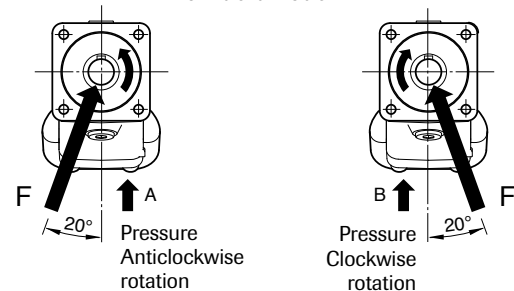

SCM SAE Max recommended shaft loads		010	012	017	025	025	034	034	040	047	056	064	084	084	108	108	130
		SAE B	SAE B	SAE B	SAE B	SAE C	SAE B	SAE C	SAE C4	SAE C	SAE C	SAE C	SAE C	SAE C	SAE D	SAE C	SAE D
Fr (radial) max ¹	kN	6.5	6.5	7	7.5	7.5	7.5	7	8.5	8.5	8.5	9	9	9	10	10	10.5
Distance D (to point of force)	mm	40	40	40	40	45	40	45	45	45	45	45	45	60	45	60	60
Fa (axial) + (at standstill/ 0 bar pressure) max	kN	3	3	3	3	3	3	3	0,5	0,5	0,5	0,5	1	1	1	1	1
Fa (axial) - (at standstill/ 0 bar pressure) max	kN	4	4	5	7	7	7	7	7	7	10	11	13	13	16	16	19
Fa (axial) + (at 400 bar pressure) max ²	kN	4	4	5	7	7	7	7	7	7	10	11	13	13	16	16	19
Fa (axial) - (at 400 bar pressure) max ²	kN	0	0	0	0	0	0	0	0	0	0	0	0	0	0	0	0

¹) Fr (radial) max; Calculation based on running conditions: 300 bar / 2000 rpm
¹) Fr (radial) max; Calculation based on optimal force direction (Fr max will be lower in other force directions)

¹) Fr (radial) max; In running conditions higher than 300 bar and/or 2000 rpm the max limits for Fr (radial) max will be lower

²) Fa (axial) + Will increase bearing life

²) Fa (axial) - Will decrease bearing life

²) When having a (high) axial force (Fa+) a sudden fall in pressure can negatively affect bearing life due to lack of compensating load and, if extreme, could lead to bearing failure.

For other forces, please contact Sunfab for advice.

Temperatures/Housing cooling

Excessive system temperature reduces the life of the shaft seal and can lower the oil viscosity below the recommended level. A system temperature of 60 °C and a drain flow temperature of 90 °C must not be exceeded.

Cooling/flushing of the motor housing can be needed to keep the drain flow temperature at an acceptable level.

Suggested flow:

Motor SCM	Flushing l/min	Cont. RPM
010-034	2-8	≥ 2800
040-064	4-10	≥ 2500
084-130	6-12	≥ 2200

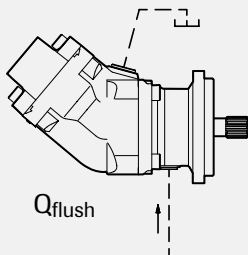

Housing flushing can be built up with the help of a flushing valve or taken directly from the return line. When the return pressure is too low this is compensated for by a counter pressure valve.

The tank line is connected to the highest point as in the figure.

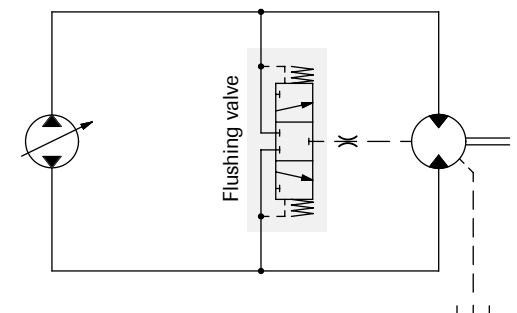
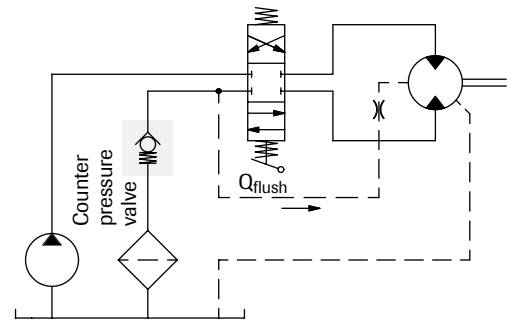
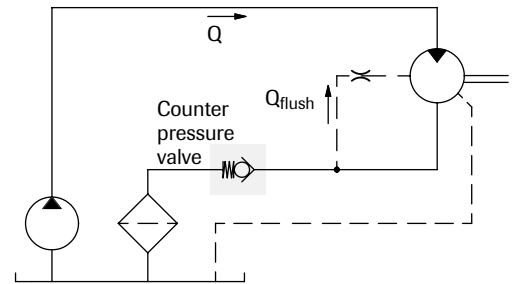

Simplified circuits

Installation

- The motor housing should be filled with oil to at least 50% before starting.
- The drainage pipe should be connected to topmost drainage outlet.
- The other end of the pipe should be connected to the oil tank at a point below the oil level.

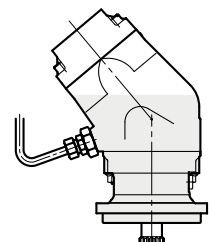
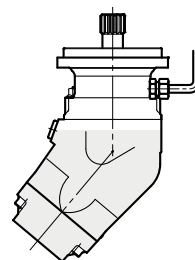
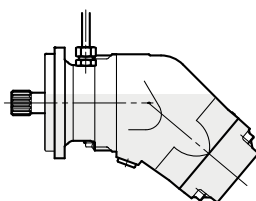
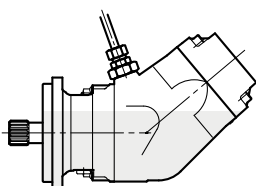

Piping

Recommended oil velocity in pressure line max. 7 m/sec

Filtering

Cleanliness according to ISO norm 4406, code 16/13.

Hydraulic fluids

High performance oils meeting ISO specifications – such as HM, DIN 51524-2 HLP, or better – must be used.

A min. viscosity of 10 cSt is required to keep the lubrication at a safe level.

The ideal viscosity is 20 - 40 cSt.

Additional technical data

Noise levels and bearing life calculations available on request. Please contact Sunfab!

Useful formulaes

Required flow rate $Q = \frac{D \times n}{1000 \times \eta_v}$ litres/min.

Speed $n = \frac{Q \times 1000 \times \eta_v}{D}$ RPM

Torque $M = \frac{D \times \Delta p \times \eta_{hm}}{6.3}$ Nm

Power $P = \frac{Q \times \Delta p \times \eta_t}{60}$ kW

D = displacement, cm³/revolution

n = speed, revolution/min

P = power, kW

Q = flow rate, litres/min

η_v = volumetric efficiency

η_{hm} = hydraulic-mechanical efficiency

η_t = overall efficiency = $\eta_v \times \eta_{hm}$

M = torque, Nm

Δp = pressure difference between the hydraulic motor inlet and outlet, MPa



WARNING!

When the motor is in use:

1. Do not touch the pressure pipe
2. Watch out for rotating parts
3. The motor and pipes can reach high temperatures

Sunfab reserves the right to make changes in design and dimensions without notice. Printing and typesetting errors reserved.

© Copyright 2021 Sunfab Hydraulics AB. All Rights Reserved.